

COMBINED SCIENCE

5129/12

Paper 1 Multiple Choice

May/June 2018

1 hour

Additional Materials: Multiple Choice Answer Sheet
 Soft clean eraser
 Soft pencil (type B or HB is recommended)



READ THESE INSTRUCTIONS FIRST

Write in soft pencil.

Do not use staples, paper clips, glue or correction fluid.

Write your name, Centre number and candidate number on the Answer Sheet in the spaces provided unless this has been done for you.

DO NOT WRITE IN ANY BARCODES.

There are **forty** questions on this paper. Answer **all** questions. For each question there are four possible answers **A, B, C** and **D**.

Choose the **one** you consider correct and record your choice in **soft pencil** on the separate Answer Sheet.

Read the instructions on the Answer Sheet very carefully.

Each correct answer will score one mark. A mark will not be deducted for a wrong answer.

Any rough working should be done in this booklet.

A copy of the Periodic Table is printed on page 16.

Electronic calculators may be used.

This document consists of **16** printed pages.

- 1 Which structures are only found in plant cells?
- A cell membrane, chloroplast and sap vacuole
 - B cell membrane, cytoplasm and nucleus
 - C cell wall, chloroplast and sap vacuole
 - D cell wall, cytoplasm and nucleus
- 2 What is the name of the process by which molecules of glucose move out of the human ileum and into the blood stream?
- A diffusion
 - B digestion
 - C peristalsis
 - D respiration
- 3 Four test-tubes contain starch solution and amylase. They are placed in water baths at different temperatures and provided with different pHs, as shown in the table.

After 30 minutes, iodine solution is added to each tube.

In which test-tube do the contents remain yellow-brown?

	temperature / °C	pH
A	35	2.5
B	35	6.9
C	75	2.5
D	75	6.9

4 The diagram shows a cross-section of a leaf.

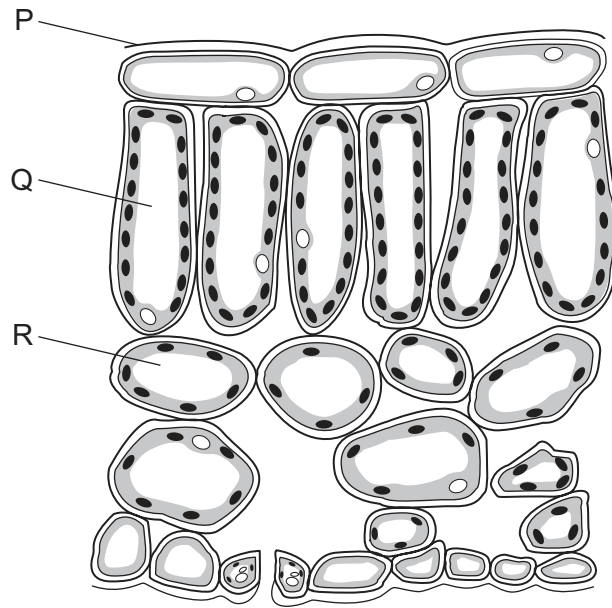

Which row correctly identifies P, Q and R?

	P	Q	R
A	cuticle	palisade cell	spongy mesophyll cell
B	cuticle	spongy mesophyll cell	palisade cell
C	stomata	palisade cell	spongy mesophyll cell
D	stomata	spongy mesophyll cell	palisade cell

5 Which row correctly describes functions of the stomach, ileum and liver?

	stomach	ileum	liver
A	absorption	assimilation	ingestion
B	digestion	absorption	assimilation
C	egestion	digestion	absorption
D	ingestion	egestion	digestion

6 What is transpiration?

- A** absorption of water by root hairs
- B** loss of water vapour from stomata
- C** movement of water up through the xylem
- D** wilting

7 Which statement about blood capillaries is **not** correct?

- A They have thin walls.
- B They have permeable walls.
- C They have valves.
- D They supply cells with oxygen.

8 What is the function of the human alveoli?

- A breathing
- B digestion
- C gas exchange
- D respiration

9 The body cannot store amino acids.

Which flow chart correctly shows what happens to excess amino acids in blood?

- A** excess amino acids in the blood → broken down in kidney → urea in the urine → travel to liver → urea in the blood
- B** excess amino acids in the blood → broken down in kidney → urea in the blood → travel to liver → urea in the urine
- C** excess amino acids in the blood → broken down in liver → urea in the urine → travel to kidney → urea in the blood
- D** excess amino acids in the blood → broken down in liver → urea in the blood → travel to kidney → urea in the urine

10 The diagram shows a section through part of a human eye.

Which structure contains the muscles that contract to control pupil size?

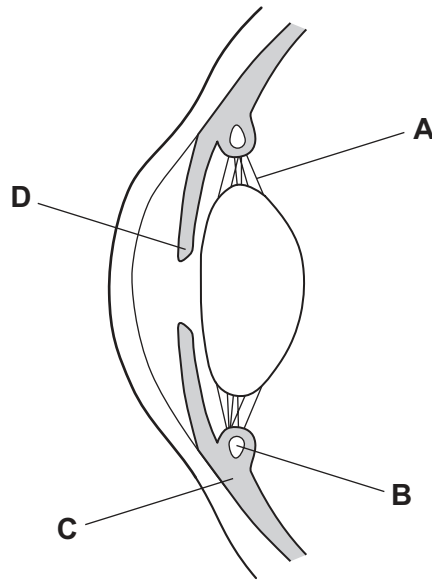

11 A student writes that taking heroin could result in four different effects.

- 1 addiction
- 2 build-up of lactic acid
- 3 stimulation
- 4 withdrawal symptoms

Which effects are correct for heroin?

- A** 1 and 2 **B** 1 and 4 **C** 2 and 3 **D** 3 and 4

12 The diagram shows a food chain.

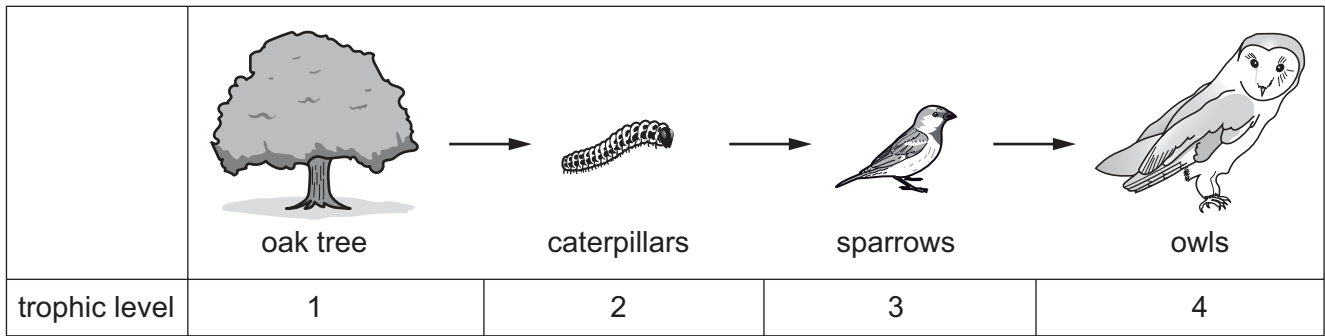

The tree has 100 000 kJ of energy.

Which row indicates the likely energy transfer between each trophic level in this food chain?

	level 1 /kJ	between 1–2 /kJ	between 2–3 /kJ	between 3–4 /kJ
A	50	500	10 000	100 000
B	50	100 000	50 000	10 000
C	100 000	10 000	500	50
D	100 000	10 000	500	500

13 Which method of birth control relies on knowing the timing of ovulation?

- A** chemical
- B** mechanical
- C** natural
- D** surgical

14 The diagrams show three sets of apparatus.

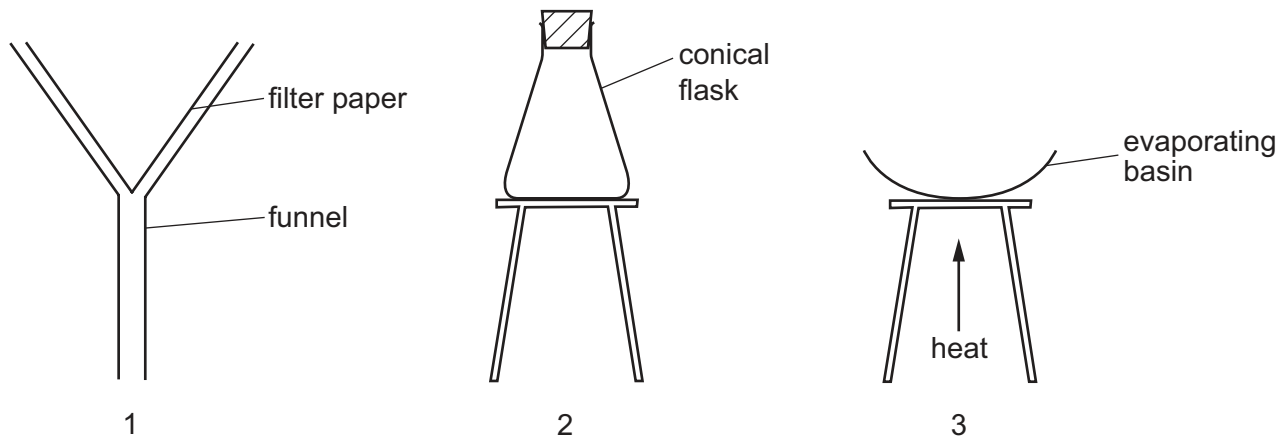

Which apparatus is used to obtain separate samples of sand and salt from a mixture of sand and salt solution?

- A** 1 and 3 **B** 1 only **C** 2 and 3 **D** 3 only

15 An atom of sodium is represented by ${}_{11}^{23}\text{Na}$.

What is the number of electrons in this atom?

- A** 11 **B** 12 **C** 23 **D** 34

16 Which statement about mixtures is correct?

- A** Brass is a mixture of different compounds.
B Crude oil is a mixture of different elements.
C Haematite is a mixture of different elements.
D Wine is a mixture of different compounds.

17 Which type of bonding occurs in the compound calcium chloride?

- A** atomic
B covalent
C ionic
D metallic

18 A compound has low electrical conductivity and high volatility.

Which type of bonding is present in the compound?

- A atomic
- B covalent
- C ionic
- D metallic

19 Aluminium oxide has the formula Al_2O_3 .

What are the formulae of the aluminium ion and the oxide ion?

	aluminium ion	oxide ion
A	Al^+	O^-
B	Al^{2+}	O^{2-}
C	Al^{2+}	O^{3-}
D	Al^{3+}	O^{2-}

20 Which balanced equation for the reaction between iron and oxygen is correct?

- A $Fe_2 + O_3 \rightarrow Fe_2O_3$
- B $2Fe + 3O \rightarrow Fe_2O_3$
- C $4Fe + 2O_2 \rightarrow 2Fe_2O_3$
- D $4Fe + 3O_2 \rightarrow 2Fe_2O_3$

21 An element forms an amphoteric oxide.

Which substances will react with an amphoteric oxide?

	acids	alkalis
A	✓	✓
B	✓	x
C	x	✓
D	x	x

key
 ✓ = reacts
 x = does not react

22 The table shows the electronic structures of five elements, V, W, X, Y and Z.

The letters are not their chemical symbols.

element	electronic structure
V	2.2
W	2.7
X	2.8.2
Y	2.8.7
Z	2.8.8

Which elements are metals in the same group?

- A** V and W **B** V and X **C** W and Y **D** X, Y and Z

23 P, Q and R are three metallic elements.

The letters are not their chemical symbols.

P does not react with dilute hydrochloric acid.

Q fizzes and produces hydrogen when added to cold water.

R produces hydrogen when added to dilute hydrochloric acid but it does not react with cold water.

What are P, Q and R?

	P	Q	R
A	aluminium	zinc	calcium
B	copper	potassium	calcium
C	copper	sodium	zinc
D	zinc	potassium	iron

24 The table shows some metals and their uses.

For which metal is the correct reason given for the stated use?

	metal	use	reason
A	aluminium	manufacture of aeroplane wings	strength and high density
B	copper	electrical wiring	good conductor of heat
C	iron	manufacturing stainless steel	rusts
D	zinc	galvanising iron	zinc is more reactive than iron

25 Which substance produces hydrogen gas when it reacts with dilute hydrochloric acid?

- A magnesium
- B magnesium carbonate
- C magnesium hydroxide
- D magnesium oxide

26 Which statement about methane and petroleum is correct?

- A Exothermic reactions occur when methane and petroleum are burned.
- B Methane and petroleum are both a mixture of alkanes.
- C Methane and petroleum are both constituents of natural gas.
- D Methane has the formula CH_4 and petroleum has the formula C_4H_{10} .

27 Alkenes are a series of unsaturated hydrocarbons containing a carbon to carbon double bond.

Which formula does **not** represent an alkene?

- A C_2H_4
- B C_3H_6
- C C_4H_{10}
- D C_6H_{12}

28 Four identical ball bearings are placed in a measuring cylinder containing water.

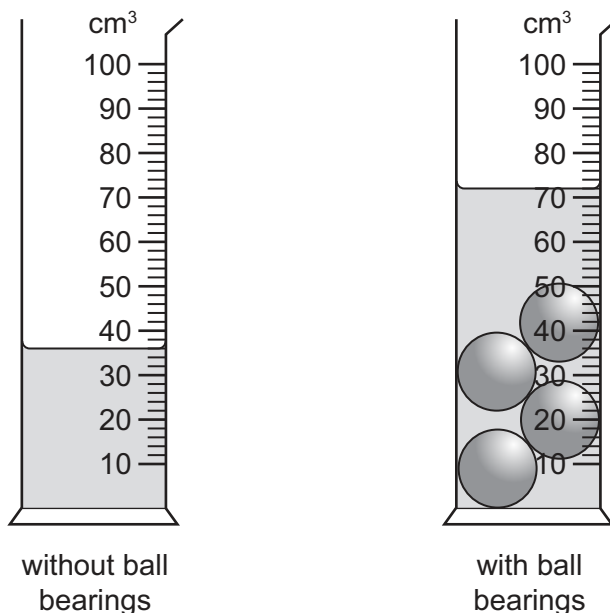

What is the volume of one ball bearing?

- A 8.75 cm^3
- B 9.00 cm^3
- C 9.50 cm^3
- D 9.75 cm^3

29 The gradient of the line on a graph gives the acceleration of a moving object.

What are the quantities on the horizontal and vertical axes of this graph?

	quantity on horizontal axis	quantity on vertical axis
A	speed	distance
B	speed	time
C	time	distance
D	time	speed

30 The diagram shows a boy of weight 500 N sitting on a see-saw. He sits 2.0 m from the pivot.

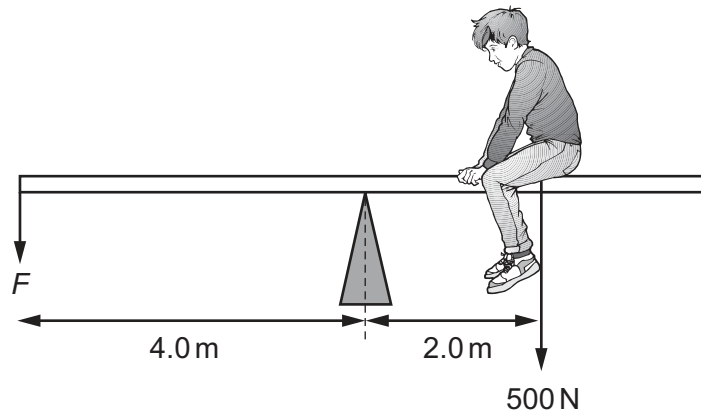

What is the force F needed to balance the see-saw?

- A** 250 N **B** 750 N **C** 1000 N **D** 3000 N

31 Jewellery can be made from metal by first heating and then hammering the metal.

What changes during the hammering action?

- A** density
B mass
C shape
D volume

- 32 Coal-fired power stations and hydroelectric power stations transfer a stored form of energy into other forms before producing electrical energy.

Which are the correct stored energies?

	coal-fired stored energy	hydroelectric stored energy
A	chemical	gravitational potential
B	chemical	kinetic
C	thermal	gravitational potential
D	thermal	kinetic

- 33 Which process is **not** involved when convection takes place in a gas?

- A** The density of the gas decreases.
- B** The separation of the molecules increases.
- C** The molecules expand.
- D** The heated gas rises.

- 34 The diagram shows the displacement of the particles in a wave.

Which value is multiplied by the frequency to give the speed of the wave?

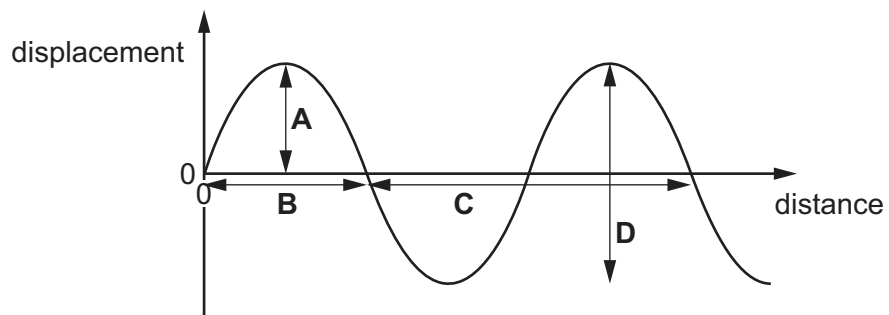

35 A ray of light is incident on the surface of a block of plastic.

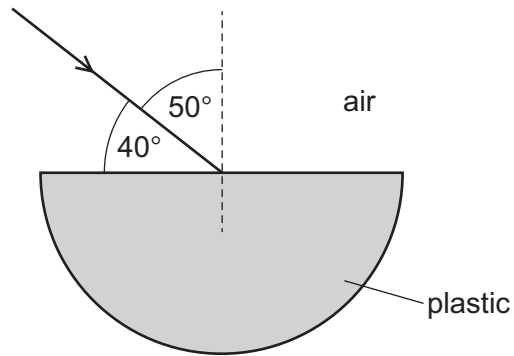

The refractive index of the plastic is 1.5.

What is the angle of refraction of the ray in the plastic?

- A** 25° **B** 27° **C** 31° **D** 33°

36 The diagram shows a lamp connected in series with a resistor.

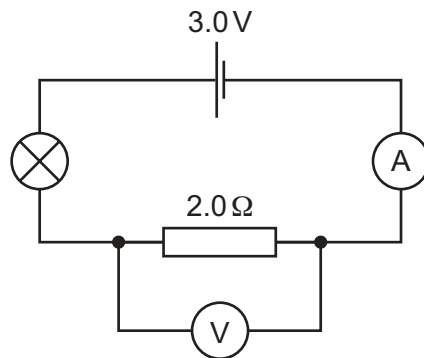

The current in the lamp is 0.5 A.

Which row gives the correct voltmeter and ammeter readings?

	voltmeter / V	ammeter / A
A	0.5	1.0
B	1.0	0.5
C	3.0	0.5
D	3.0	1.5

37 A student sets up the circuit shown.

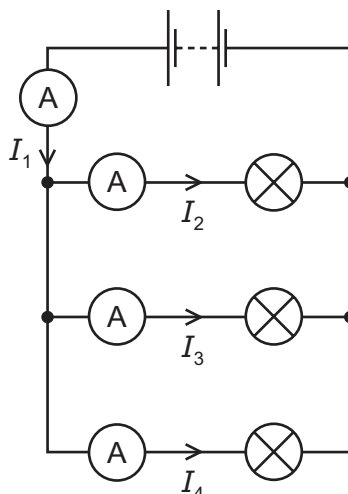

The currents measured by the ammeters are shown.

Which equation is correct?

- A** $I_1 = I_2 + I_3 + I_4$
- B** $I_1 = I_2 = I_3 = I_4$
- C** $I_2 + I_3 = I_4 + I_1$
- D** $I_4 = I_3 + I_2 + I_1$
- 38 When a correctly wired plug is used to connect a working device to the mains, which statement is **not** correct?
- A** The fuse is in the live wire connection to the mains.
- B** The switch is in the live wire connection to the mains.
- C** The value of the fuse is just larger than the current.
- D** There is current in the earth wire.
- 39 The symbol for a nuclide is ${}^{87}_{37}\text{X}$. X represents the symbol for any chemical element.

Another nuclide has the same number of neutrons but one more proton.

What is the symbol for this other nuclide?

- A** ${}^{87}_{36}\text{X}$ **B** ${}^{87}_{38}\text{X}$ **C** ${}^{88}_{37}\text{X}$ **D** ${}^{88}_{38}\text{X}$

40 The diagram shows the penetrative powers of three types of radiation.

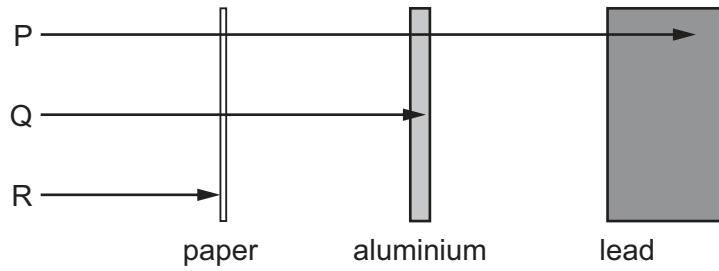

Which row correctly identifies each radiation?

	P	Q	R
A	beta	alpha	gamma
B	beta	gamma	alpha
C	gamma	alpha	beta
D	gamma	beta	alpha

Permission to reproduce items where third-party owned material protected by copyright is included has been sought and cleared where possible. Every reasonable effort has been made by the publisher (UCLES) to trace copyright holders, but if any items requiring clearance have unwittingly been included, the publisher will be pleased to make amends at the earliest possible opportunity.

To avoid the issue of disclosure of answer-related information to candidates, all copyright acknowledgements are reproduced online in the Cambridge International Examinations Copyright Acknowledgements Booklet. This is produced for each series of examinations and is freely available to download at www.cie.org.uk after the live examination series.

Cambridge International Examinations is part of the Cambridge Assessment Group. Cambridge Assessment is the brand name of University of Cambridge Local Examinations Syndicate (UCLES), which is itself a department of the University of Cambridge.

The Periodic Table of Elements

		Group																				
I	II	III	IV	V	VI	VII	VIII															
3 Li lithium 7	4 Be beryllium 9	11 Na sodium 23	12 Mg magnesium 24	19 K potassium 39	20 Ca calcium 40	21 Sc scandium 45	22 Ti titanium 48	23 V vanadium 51	24 Cr chromium 52	25 Mn manganese 55	26 Fe iron 56	27 Co cobalt 59	28 Ni nickel 59	29 Cu copper 64	30 Zn zinc 65	31 Ga gallium 70	32 Ge germanium 73	33 As arsenic 75	34 Se selenium 79	35 Br bromine 80	36 Kr krypton 84	
37 Rb rubidium 85	38 Sr strontium 88	39 Y yttrium 89	57-71 lanthanoids	72 Hf hafnium 178	73 Ta tantalum 181	74 W tungsten 184	75 Re rhenium 186	76 Os osmium 190	77 Ir iridium 192	78 Pt platinum 195	79 Au gold 197	80 Hg mercury 201	81 Tl thallium 204	82 Pb lead 207	83 Bi bismuth 209	84 Po polonium —	85 At astatine —	86 Rn radon —				
87 Fr francium —	88 Ra radium —	89 Ac actinium —	89-103 actinoids	104 Rf rutherfordium —	105 Db dubnium —	106 Sg seaborgium —	107 Bh bohrium —	108 Hs hassium —	109 Mt meitnerium —	110 Ds darmstadtium —	111 Rg roentgenium —	112 Cn copernicium —	114 Fl flerovium —	116 Lv livermorium —								
		Key atomic number atomic symbol name relative atomic mass		1 H hydrogen 1																		

lanthanoids	57 La lanthanum 139	58 Ce cerium 140	59 Pr praseodymium 141	60 Nd neodymium 144	61 Pm promethium —	62 Sm samarium 150	63 Eu europium 152	64 Gd gadolinium 157	65 Tb terbium 159	66 Dy dysprosium 163	67 Ho holmium 165	68 Er erbium 167	69 Tm thulium 169	70 Yb ytterbium 173	71 Lu lutetium 175
actinoids	89 Ac actinium —	90 Th thorium 232	91 Pa protactinium 231	92 U uranium 238	93 Np neptunium —	94 Pu plutonium —	95 Am americium —	96 Cm curium —	97 Bk berkelium —	98 Cf californium —	99 Es einsteinium —	100 Fm fermium —	101 Md mendelevium —	102 No nobelium —	103 Lr lawrencium —

The volume of one mole of any gas is 24 dm³ at room temperature and pressure (r.t.p.).